

5 KEYS TO GOOD SIGNALLING

During the whole guiding operation, the banksman must:

- 1- Refrain from telephoning, chatting,...
- 2- Keep out of the clearance area of manoeuvring vehicles and machinery.
- 3- Stand away from any obstacle: machinery, post, wall, trench, safety barrier.
- 4- Make large but precise signals.
- 5- Finish all manoeuvres by giving the "operations end" signal.

POSITION OF THE BANKSMAN WITH RESPECT TO THE VEHICLE HE IS GUIDING

For the whole guiding operation, the banksman must make sure he is seen at all times by the drivers:

- 1- He must not be standing in any of the vehicle's blind spots (diagrams 1 and 2)
- 2- He must not be standing in the vehicle's trajectory (diagrams 3 and 4).

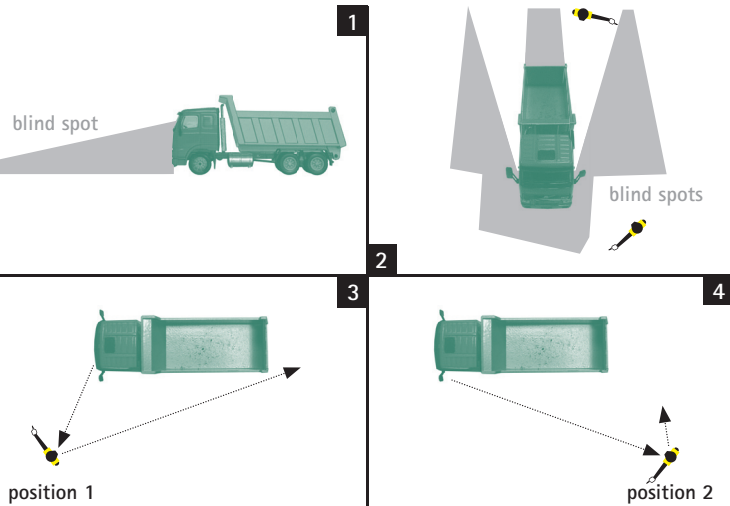

3 and 4: positions 1 and 2 the banksman can see behind the vehicle and can be seen by the driver.

© 2007 Renaud Paumero, www.inbloem.fr - doc version 1



OPERATIONS START

One arm dropped, the other raised vertically, hand open, palm outwards.



1
2



REVERSING

Banksman in front of the vehicle: arms bent, palms down, gesture away from body.

Banksman behind the vehicle: arms bent, palms up, gesture towards the body.



REVERSING TO THE RIGHT

Right arm horizontal pointing to the right, left arm making reversing signal.



REVERSING TO THE LEFT

Left arm horizontal pointing to the left, right arm making reversing signal.



3
4



SHOWING DISTANCE BEHIND THE VEHICLE

Arms bent, palms facing, show distance by bringing arms slowly together.



STOP REVERSING

Cross and uncross arms in front of body.



5
6



RAISE DUMPER BODY

Arm bent, thumb pointing upwards.



LOWER DUMPER BODY

Arm bent, thumb pointing downwards.



STOP RAISING DUMPER BODY

Cross and uncross arms horizontally in front of body.



OPERATIONS END

Arms outstretched horizontally, palms facing driver.



7
8

8 Recommended Signals for Safe Manoeuvring



Why this guide?

Our building sites with all the manoeuvring of machinery and vehicles can lead to serious or even fatal accidents. This is why all the persons involved in the site have a role to play:

- **Site managers** and contract managers organise the site.
- **Drivers** ensure the conformity of their vehicles.
- **Pedestrians** are vigilant in all circumstances.

This guide encompasses the safety instructions required to ensure that pedestrians, machinery and vehicles can work together safely on a building site and namely includes the 8 recommended signals to ensure safe manoeuvring.

Safety instructions

SITE MANAGERS:

An organised site is a safe site!

- Establish and maintain the traffic plan (traffic routes and one-way systems, site entrances and exits, parking and storage areas,...).
- Define and maintain speed limits.
- Identify hazardous areas and prevent their access to personnel on foot.

Reversing = danger !

- Where possible, eliminate the need for reversing.
- Organise routes to minimise reversing distances.
- Identify and mark out areas where reversing and manoeuvring may be performed safely.

Information for implementation!

- Inform all the personnel (including drivers from transport companies) of the hazards linked to the movement of pedestrians, vehicles and machinery on site.
- Communicate the traffic rules and safety instructions: traffic plan and site specific instructions.

PEDESTRIANS:

Make sure you are visible and vigilant!

- Always wear hi-visibility clothing.
- Make sure drivers of vehicles and machinery know of your presence.
- Make sure you have been seen by catching the driver's eye.
- Keep your distance from areas where vehicles are manoeuvring.
- Be extremely alert at all times.

If necessary, ask the driver to let you climb up into the cab, vehicle at a standstill, so as to see the blind spots for yourself.

DRIVERS:

You are responsible for your vehicles and machinery!

- Before starting work for the day, ensure the conformity of your vehicles and machinery:
- Check that external rear view mirrors and windows are clean and in good condition.
 - Check that audible reversing alarms and warning lights, and reversing radar or cameras if any, are fully operational.

Guiding Difficult Manoeuvres

Manoeuvring vehicles and machinery is both difficult and dangerous. Whenever conditions of visibility are poor, the driver of a vehicle or machinery must be guided by a banksman (signaller).

BANKSMAN:

Before the manoeuvre:

A banksman must be designated for the manoeuvre, either by agreement between the driver and a skilled worker, or by the site manager. He must then:

- Ensure that the recommended guiding signals used are seen and understood by the driver.
- Stand in a safe position outside the manoeuvring area.
- Verify that nothing is obscuring the visibility of driver or banksman.
- Start each manoeuvre by using the «operations start» signal.

During the manoeuvre:

During the manoeuvre, he must:

- Only use recommended signals.
- Ensure that there are no pedestrians or obstacles within the manoeuvring area and prevent access.
- Make sure he can always be seen by the driver.
- Guide the driver during the whole manoeuvre.
- In case of emergencies, cause the vehicle to stop immediately using the "STOP" command.

DRIVER:

Before the manoeuvre:

Before the manoeuvre, the driver is familiar with:

- The traffic conditions on the site.
- The 8 recommended signals.

During the manoeuvre:

During the manoeuvre, he must:

- Follow the banksman's indications.
- Perform any manoeuvres under the orders and guidance of a banksman.
- Stop immediately if he loses sight of the banksman.
- Be extremely attentive.

